



English

Quick Installation Guide

CFW300 Micro Drive



1 SAFETY INSTRUCTIONS

This quick installation guide contains the basic information necessary to commission the CFW300. It has been written to be used by qualified personnel with suitable training or technical qualification for operating this type of equipment. The personnel must follow all the safety instructions described in this manual defined by the local regulations. Failure to comply with the safety instructions may result in death, serious injury, and/or equipment damage.

2 SAFETY WARNINGS IN THE MANUAL AND IN THE PRODUCT

NOTE! It is not the intention of this guide to present all the possibilities for the application of the CFW300, as well as WEG cannot take any liability for the use of the CFW300 which is not based on this guide. For further information about installation, full parameter list and recommendations, visit the website www.weg.net.

DANGER! The procedures recommended in this warning have the purpose of protecting the user against death, serious injuries and considerable material damage.

ATTENTION! The procedures recommended in this warning have the purpose of avoiding material damage.

NOTE! The information mentioned in this warning is important for the proper understanding and good operation of the product.

High voltages are present.

Components sensitive to electrostatic discharge. Do not touch them.

Mandatory connection to the protective ground (PE).

Connection of the shield to the ground.

3 PRELIMINARY RECOMMENDATIONS

DANGER! Always disconnect the main power supply before touching any electrical component associated to the inverter. Several components can remain charged with high voltages or remain in movement (fans) even after the AC power is disconnected or switched off. Wait at least ten minutes after turning off the input power for the complete discharge of the power capacitors. Always connect the grounding point of the inverter to the protection earth (PE). The XC10 connector is not USB compatible, therefore, it cannot be connected to USB ports. This connectors serve only as interface between the CFW300 frequency inverter and its accessories.

NOTE! Frequency Inverter may interfere with other electronic equipment. Follow the precautions recommended in user's manual available for download on the website: www.weg.net.

Do not perform any withstand voltage test (hi-pot test)! If necessary, contact WEG.

ATTENTION! Electronic boards have components sensitive to electrostatic discharges. Do not touch directly on components or connectors. If necessary, first touch the grounding point of the inverter, which must be connected to the protection earth (PE) or use a proper grounding strap.

DANGER! This product was not designed to be used as a safety element. Additional measures must be taken so as to avoid material and personal damages. The product was manufactured under strict quality control, however, if installed in systems where its failure causes risks of material or personal damages, additional external safety devices must ensure a safety condition in case of a product failure, preventing accidents.

4 ABOUT THE CFW300

The CFW300 frequency inverter is a high-performance product which allows speed and torque control of three-phase induction motors. This product provides the user with the options of vector (V/V) or scalar (V/f) control, both programmable according to the application.

5 TERMINOLOGY

Table 1: Terminology of the CFW300 inverters

Product and Series	Model Identification				Degree of Protection	Hardware Version	Software Version
	Frame Size	Rated Current	Phase Number	Rated Voltage			
Ex.: CFW300	A	01P6	S	2	NB	---	---
Available options	Refer to Table 2					Blank = standard	Sx = special software
	NB = without dynamic braking DB = with dynamic braking 20 = IP20						

NOTE! **200 V Line:** Models with power supply of 110 to 127 Vac, 200 to 240 Vac or 280 to 340 Vdc (S1, S2, B2, T2 or D3). **400 V Line:** Models with power supply of 380 to 480 Vac or 513 to 650 Vdc (T4).

Table 2: Available options for each field of the nomenclature according to the rated current and voltage of the inverter

Frame Size	Output Rated Current	N° of Phases	Rated Voltage	Brake
A	01P6 = 1.6 A	S = single-phase power supply	1 = 110...127 Vac	NB
	02P6 = 2.6 A			
	04P2 = 4.2 A			
	06P0 = 6.0 A			
	01P6 = 1.6 A			
	02P6 = 2.6 A			
	04P2 = 4.2 A			
	06P0 = 6.0 A			
	07P3 = 7.3 A	T = three-phase power supply	2 = 200...240 Vac	NB
	01P6 = 1.6 A			
	02P6 = 2.6 A			
	04P2 = 4.2 A			
06P0 = 6.0 A				
07P3 = 7.3 A				
01P6 = 1.6 A	D = DC power supply	3 = 280...340 Vdc	NB	
02P6 = 2.6 A				
04P2 = 4.2 A				
06P0 = 6.0 A				
07P3 = 7.3 A				
07P3 = 7.3 A				
B	10P0 = 10.0 A	B = single-phase or three-phase power supply or DC	2 = 200...240 Vac or 280...340 Vdc	DB
	15P2 = 15.2 A			
	01P1 = 1.1 A	T = three-phase power supply	4 = 380...480 Vac	NB
	01P8 = 1.8 A			
02P6 = 2.6 A				
03P5 = 3.5 A				
C	06P5 = 6.5 A	T = three-phase power supply or DC	4 = 380...480 Vac or 513...650 Vdc	DB
	08P2 = 8.2 A			
	10P0 = 10.0 A			
	12P0 = 12.0 A			
B	01P1 = 1.1 A	T = three-phase power supply or DC	4 = 380...480 Vac or 513...650 Vdc	DB
	01P8 = 1.8 A			
	02P6 = 2.6 A			
	03P5 = 3.5 A			
C	06P5 = 6.5 A	T = three-phase power supply or DC	4 = 380...480 Vac or 513...650 Vdc	DB
	08P2 = 8.2 A			
	10P0 = 10.0 A			
	12P0 = 12.0 A			
C	15P0 = 15.0 A	T = three-phase power supply or DC	4 = 380...480 Vac or 513...650 Vdc	DB
	01P1 = 1.1 A			
	01P8 = 1.8 A			
	02P6 = 2.6 A			

6 RECEIVING AND STORAGE

The CFW300 is supplied packed in a cardboard box. There is an identification label affixed to the outside of the package, identical to the one affixed to the side of the inverter.

Verify whether:

- The CFW300 identification label corresponds to the purchased model.
- Any damage occurred during transportation.

Report any damage immediately to the carrier.

If the CFW300 is not installed soon, store it in a clean and dry location (temperature between -25 °C and 60 °C (-13 °F and 140 °F)), with a cover to prevent dust accumulation inside it.

ATTENTION! When the inverter is stored for a long period, it becomes necessary to perform the capacitor reforming. Refer to the procedure recommended in user's manual, available for download on the website: www.weg.net.

7 IDENTIFICATION LABEL

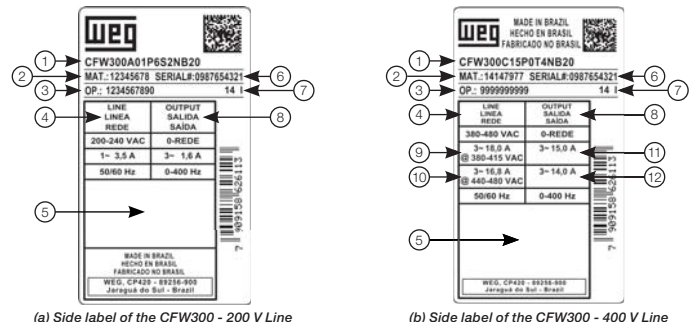

- (1) Model (inverter intelligent code).
- (2) WEG stock item.
- (3) Production order.
- (4) Rated input data (voltage, current and frequency).
- (5) Certifications.
- (6) Serial number.
- (7) Manufacturing date (14 corresponds to the week and 1 to the year).
- (8) Rated output data (voltage, current and frequency).
- (9) Input current for voltage range 1 (*).
- (10) Input current for voltage range 2 (**).
- (11) Output current for voltage range 1 (*).
- (12) Output current for voltage range 2 (**).
- (*) Voltage Range 1: Rated currents specified for mains power supply voltages of 380-400-415 Vac (513-540-560 Vdc).
- (**) Voltage Range 2: Rated currents specified for mains power supply voltages of 440-460-480 Vac (594-621-650 Vdc).

Figure 1: (a) and (b) Description of the CFW300 identification label

8 MECHANICAL INSTALLATION

8.1 ENVIRONMENTAL CONDITIONS

Avoid:

- Direct exposure to sunlight, rain, high humidity or sea-air.
- Inflammable or corrosive gases or liquids.
- Excessive vibration.
- Dust, metallic particles or oil mist.

Environment conditions permitted for the operation of the inverter:

- Temperature around the inverter (IP20): **200 V Line:** from 0 °C to 50 °C (32 °F to 122 °F). **400 V Line:** from 0 °C to 40 °C (32 °F to 104 °F). For more details, refer to Table 10.
- For temperatures surrounding the inverter higher than the specifications above, it is necessary to apply 2 % of current derating for each degree Celsius (1.1 % for each degree Fahrenheit), limited to an increase of 10 °C (18 °F).
- Air relative humidity: 5 % to 95 % non-condensing.
- Maximum altitude: up to 1000 m (3,300 ft) - rated conditions.
- From 1000 m to 4000 m (3,300 ft to 13,200 ft) - 1 % of current derating for each 100 m (330 ft) above 1000 m (3,300 ft) of altitude.
- From 2000 m to 4000 m (6,600 ft to 13,200 ft) above sea level - maximum voltage derating (127 V / 240 V / 480 V, according to the model, as indicated in Table 10) of 1.1 % for each 100 m (330 ft) above 2000 m (6,600 ft).
- Pollution degree: 2 (according to EN50178 and UL508C), with non-conductive pollution. Condensation must not originate conduction through the accumulated residues.

8.2 DIMENSIONS, POSITIONING AND MOUNTING

The external dimensions and fixing holes, likewise the inverter net weight (mass) are shown in Figure 2.

Mount the inverter in the upright position on a flat and vertical surface. Allow the minimum clearances indicated in Figure 3, in order to allow the circulation of the cooling air. Do not install heat sensitive components right above the inverter.

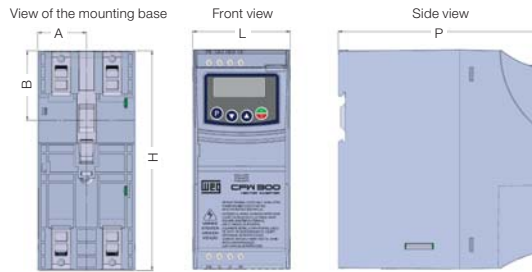

Frame Size	A	B	H	L	P	Weight	Mounting Bolt	Recommended Torque
								N.m (lbf.in)
A	35.0 (1.37)	50.1 (1.97)	157.9 (6.22)	70.0 (2.76)	148.4 (5.84)	0.900 (1.96)	M4	2 (17.7)
B	35.0 (1.37)	50.1 (1.97)	198.9 (8.08)	70.0 (2.76)	158.4 (6.24)	1.340 (2.99)	M4	2 (17.7)
C	44.5 (1.75)	50.1 (1.97)	214.0 (8.43)	89.0 (3.50)	164.0 (6.45)	1.50 (3.3)	M4	2 (17.7)

Dimension tolerance: ±1.0 mm (±0.039 in)

Figure 2: Inverter dimensions for mechanical installation



(a) Surface mounting (b) DIN rail mounting

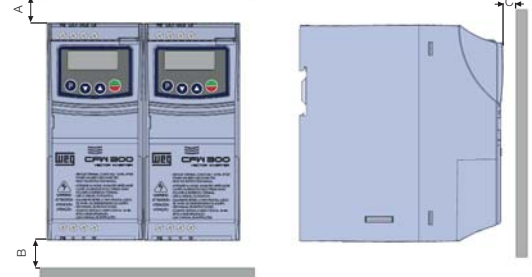

(c) Minimum ventilation free spaces

Frame Size	A	B	C
	mm (in)	mm (in)	mm (in)
A	15 (0.59)	40 (1.57)	30 (1.18)
B	35 (1.38)	50 (1.97)	40 (1.57)
C	40 (1.57)	50 (1.97)	50 (1.97)

Dimension tolerance: ±1.0 mm (±0.039 in)

Figure 3: (a) to (c) Mechanical installation data (surface mounting and minimum ventilation free spaces)

ATTENTION! When installing two or more inverters vertically, respect the minimum clearance A + B (as shown in Figure 3) and provide an air deflecting plate so that the heat rising up from the lower inverter does not affect the top inverter. Provide independent conduits for the physical separation of signal, control and power cables (refer to Chapter 9 ELECTRICAL INSTALLATION).

8.3 CABINET MOUNTING

For inverters installed inside cabinets or metallic boxes, provide proper exhaustion, so that the temperature remains within the allowed range. As a reference, Table 3 shows the air flow of rated ventilation for each model.

Cooling Method: internal fan with air flow upwards.

Table 3: Air flow of the internal fan

Model	CFM	l/s	m³/min
A	17.0	8.02	0.48
B			
C	40.43	19.09	1.15

8.4 SURFACE MOUNTING

Figure 3 illustrates the CFW300 installation procedure for surface mounting. The bolts and the tightening torque used for mounting the inverter CFW300 on the surface are specified in Figure 2.

8.5 DIN-RAIL MOUNTING

The CFW300 inverter can also be mounted directly on a 35 mm-rail, in accordance with DIN EN 50.022. Figure 3 illustrates the installation procedure of the CFW300 in DIN rail.

9 ELECTRICAL INSTALLATION

DANGER! The following information is merely a guide for proper installation. Comply with applicable local regulations for electrical installations. Make sure the AC power supply is disconnected before starting the installation. The CFW300 must not be used as an emergency stop device. Provide other devices for that purpose.

ATTENTION! Integral solid state short circuit protection does not provide branch circuit protection. Branch circuit protection must be provided in accordance with applicable local codes.

9.1 IDENTIFICATION OF THE POWER TERMINALS AND GROUNDING POINTS

The power terminals can be of different sizes and configurations, depending on the model of the inverter, according to Figure 4. The maximum tightening torque of the power terminals and grounding points must be checked in Figure 4.

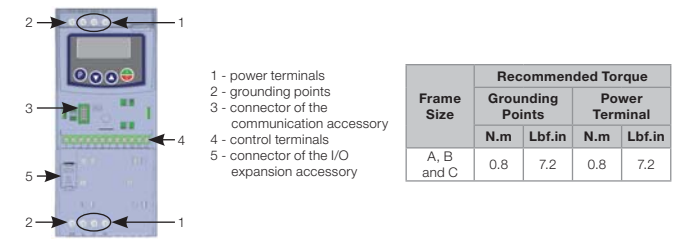

Figure 4: Power terminals, grounding points and recommended tightening torque

Description of the power terminals: **L/L1, N/L2, L3 (R,S,T):** power supply connection. **U, V and W:** connection for the motor. **-UD:** negative pole of the DC power supply. **+UD:** positive pole of the DC power supply. **-BR, BR:** connection of the braking resistor (available for DB models). **PE:** grounding connection.

DANGER! Observe the correct DC power supply connection, polarity and terminal positions.

9.2 CIRCUIT BREAKERS, FUSES, GROUNDING AND POWER CABLES

ATTENTION! Use proper cable lugs for the power and grounding connection cables. Refer to Table 10 for recommended wiring, circuit breakers and fuses. Keep sensitive equipment and wiring at a minimum distance of 0.25 m (9.85 in) from the inverter and from the cables connecting the inverter to the motor.

NOTE! The wire gauges listed in Table 10 are guiding values. Installation conditions and the maximum permitted voltage drop must be considered for the proper wiring sizing. For compliance with UL standard, use UL class J fuses or circuit breakers in the inverter power supply with current not above the values indicated in Table 10.

9.3 POWER CONNECTIONS

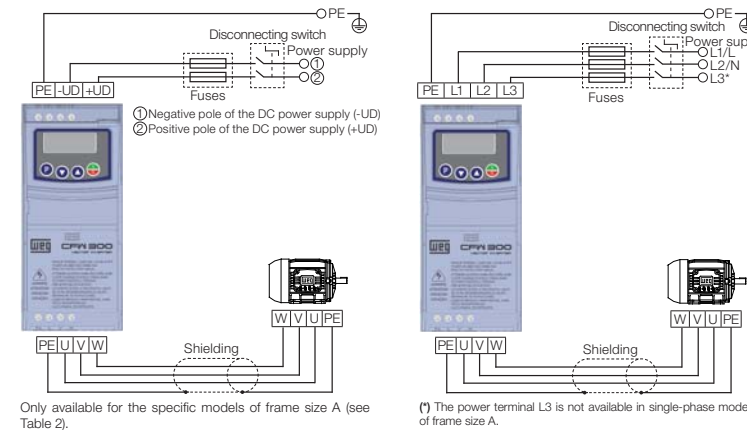

(a) Frame size A DC power supply

(b) Frame size A single-phase and three-phase power supply

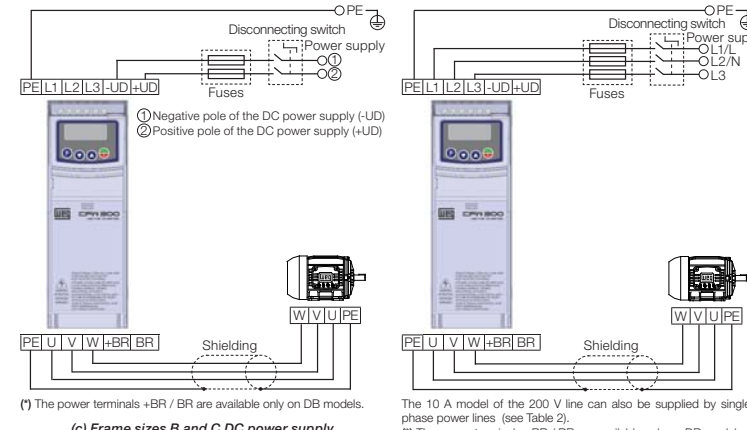

(c) Frame sizes B and C DC power supply

(d) Frame sizes B and C three-phase power supply

Figure 5: (a) to (d) Power and grounding connections

DANGER! Provide a disconnect device for the inverter power supply. This device must cut off the power supply whenever necessary (during maintenance for instance).

ATTENTION! The power supply that feeds the inverter must have a solid grounded neutral. The CFW300 series inverter must not be used in IT networks (neutral is not grounded or grounded provided by a high ohm value resistor) or in grounded delta networks ("delta corner grounded"), because these type of networks damage the inverter.

NOTE! The input power supply voltage must be compatible with the inverter rated voltage. Power factor correction capacitors are not needed at the input (L/L1, N/L2, L3) and must not be installed at the output (U, V, W).

9.3.1.1 Short Circuit Current Ratings (SCCR)

- The CFW300 is suitable for use in circuits capable of delivering not more than (see column "SCCR") kA symmetrical (127 V, 240 V or 480 V), when protected by fuses or circuit breakers as specified in Table 10.
In case the CFW300 is installed in power supplies with current capacity over the specified, it is necessary to use protection circuits, such as fuses or circuit breakers, proper for those power supplies.

ATTENTION! The opening of the branch-circuit protective device may be an indication that a fault current has been interrupted. To reduce the risk of fire or electric shock, current-carrying parts and other components of the inverter or cabinet should be examined and replaced if damaged. If burnout of the current element of an overload relay occurs, the complete overload relay must be replaced.

9.3.2 Power Supply Reactance

In order to prevent damages to the inverter and assure the expected useful life, you must have a minimum line impedance that provides a line voltage drop of 1 %. For more details, refer to the user's manual available at www.weg.net.

9.3.3 Dynamic Braking

NOTE! The dynamic braking is available on DB models from frame size B onwards.

Refer to Table 10 for the following specifications of the dynamic braking: maximum current, minimum braking resistance, rms current and cable gauge.

Refer to the user's manual available at www.weg.net for correct installation, sizing and protection.

9.3.4 Output Connections

The characteristics of the cable used to connect the motor to the inverter, as well as its interconnection and routing, are extremely important to avoid electromagnetic interference in other equipment. Keep motor cables away from other cables (signal cables, sensor cables, control cables, etc.), according to Table 4. For more information, refer to the user's manual available at www.weg.net.

9.4 GROUNDING CONNECTIONS

DANGER! The inverter must be connected to a protective ground (PE). Use a minimum wire gauge for ground connection equal to the indicated in Table 10. Connect the inverter grounding connections to a ground bus bar, to a single ground point or to a common grounding point (impedance <= 10 Ohm). The neutral conductor of the line that feeds the inverter must be solidly grounded; however this conductor must not be used to ground the inverter. Do not share the grounding wiring with other equipment that operate with high currents (e.g.: high voltage motors, welding machines, etc.).

9.5 CONTROL CONNECTIONS

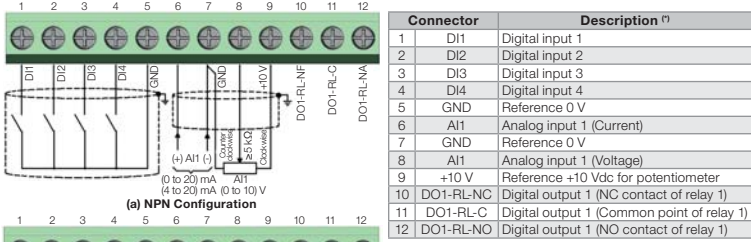

Figure 6: (a) and (b) Signals of C300 control card connector. (a) NPN Configuration, (b) PNP Configuration.

- For the correct connection of the control, use: 1. Gauge of the cables: 0.5 mm² (20 AWG) to 1.5 mm² (14 AWG). 2. Maximum torque: 0.4 N.m (3.54 lbf.in). 3. Wiring of the connector of the control board with shielded cable and separated from the other wiring (power, command) in 110 V / 220 Vac, etc.). 4. Relays, contactors, solenoids or coils of electromechanical brake installed close to the inverters may occasionally generate interference in the control circuitry. To eliminate this effect, RC suppressors (with AC power supply) or freewheel diodes (with DC power supply) must be connected in parallel to the coils of these devices. 5. Provide separation between the control and the power cables according to Table 4.

Table 4: Separation distance between cables

Table with 3 columns: Output Rated Current of the inverter, Cable Length, Minimum Separation Distance. Values range from <= 24 A to > 100 m (330 ft).

9.6 INSTALLATIONS ACCORDING TO EUROPEAN DIRECTIVE OF ELECTROMAGNETIC COMPATIBILITY

The CFW300 inverter series, when properly installed, meet the requirements of the directive of the electromagnetic compatibility (2014/30/EU).

These inverters were developed for professional applications only. Therefore, the emission limits of harmonic currents established by the EN 61000-3-2 and EN 61000-3-2/A 14 standards are not applicable.

9.6.1 Conformal Installation

- Shielded output cables (motor cables) with shield connected at both ends, motor and inverter, by means of a low impedance to high frequency connection. Maximum motor cable length and conducted and radiated emission levels according to Table 7. 2. Shielded control cables, keeping the separation distance from other cables according to Table 4. 3. Grounding of the inverter according to instructions of the Section 9.4 GROUNDING CONNECTIONS. 4. Grounded power supply. 5. Use short wiring to ground the external filter or inverter. 6. Ground the mounting plate using a flexible braid as short as possible. Flat conductors have lower impedance at high frequencies. 7. Use cord grips for strain relief on conduits.

9.6.2 Emission and Immunity Levels

Table 5: Emission and immunity levels. Columns: EMC Phenomenon, Basic Standard, Level. Rows include Mains terminal disturbance voltage, Electromagnetic radiation disturbance, Immunity, Electrostatic discharge (ESD), Fast transient-Burst, Conducted Radio-Frequency Common Mode, Surges, Radio-Frequency Electromagnetic Field.

Definition of Standard IEC/EN 61800-3: "Adjustable Speed Electrical Power Drives Systems"

Environments: First Environment: environments that include domestic installations, as well as establishments directly connected without intermediate transformer to a low-voltage power supply network which supplies buildings used for domestic purposes. Second Environment: includes all establishments other than those directly connected to a low-voltage power supply network that supplies buildings used for domestic purposes. Categories: Category C1: inverters with a voltage rating less than 1000 V and intended for use in the First Environment. Category C2: inverters with a voltage rating less than 1000 V intended for use in the First Environment, not provided with a plug connector or movable installations. They must be installed and commissioned by a professional. Category C3: inverters with a voltage rating less than 1000 V and intended for use in the Second Environment only (not designed for use in the First Environment).

NOTE! A professional is a person or organization familiar with the installation and/or commissioning of inverters, including their EMC aspects.

9.6.3 Characteristics of the RFI Filter

CFW300 inverters, when installed with external filter, comply with the directive for electromagnetic compatibility (2014/30/EU). The use of RFI filter kit indicated in the table 6, or equivalent, is required to reduce the disturbance conducted from the inverter to the power line in the high frequency band (> 150 kHz) observing the maximum conducted emission levels of electromagnetic compatibility standards, such as EN 61800-3.

For further information about the RFI filter kit accessory model, refer to Table 6.

The Figure 7 demonstrate the connection of the filter to the inverter:

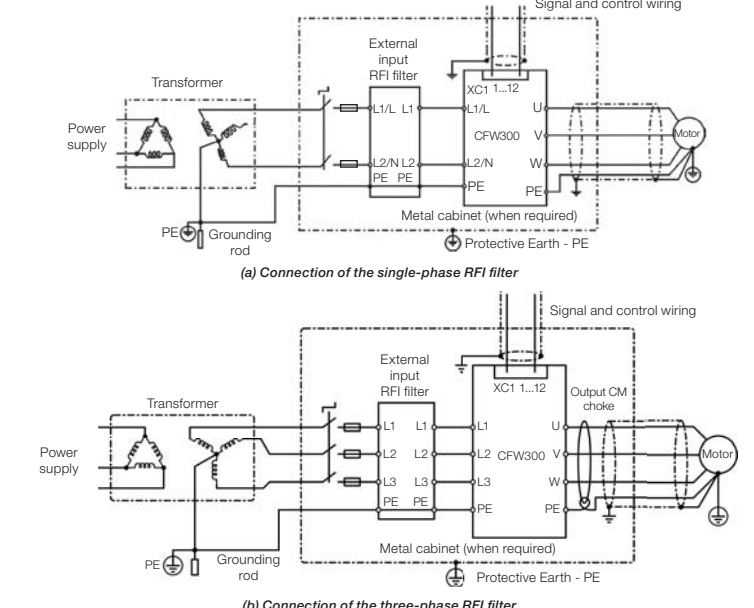

Figure 7: (a) and (b) Connection of the RFI filter - general conditions

Table 6: External RFI filter models for CFW300

Table with 3 columns: WEG Item, Name, Description. Lists various RFI filter models like CFW300-KFA-S1-S2, CFW300-KFB-S2, etc.

Table 7: Conducted and radiated emission levels, and additional information

Table with 5 columns: Inverter Model, Switching Frequency, Conducted Emission - Maximum Motor Cable Length (Category C3, Category C2), Radiated Emission Category. Includes rows for 200 V Line and 400 V Line.

(1) For the models of 400 V Line, use the ferrite available with the RFI filter accessory on the motor cables (according to Table 6). (2) Where there is an "X", it is assumed as any corresponding value of Table 2.

9.7 ACCESSORIES

The accessories are hardware resources that can be added to the application with the CFW300. The accessories are incorporated to the inverters in an easy and quick way by using the "Plug and Play" concept. The accessory must be installed or modified with the inverter de-energized. They may be ordered separately, and will be shipped in individual packages containing the components and manuals with detailed instructions for their installation, operation and setting.

For the list of accessories available for the CFW300, see Chapter 7 of the user's manual, available at www.weg.net.

10 TECHNICAL SPECIFICATIONS

10.1 POWER DATA

- Power Supply: Tolerance: -15 % to +10%. Frequency: 50/60 Hz (48 Hz to 62 Hz). Phase imbalance: <= 3 % of the rated phase-to-phase input voltage. Overvoltage according to Category III (EN 61010/UL508C). Transient voltages according to Category III. Maximum of 10 connections per hour (1 every 6 minutes). Typical efficiency: >= 97 %. Classification of chemically active substances: level 3C2. Mechanical condition rating (vibration): level 3M4. Audible noise level: < 60dB.

10.2 ELECTRONICS/GENERAL DATA

Table 8: Electronics/general data. Columns: Control, Performance, Inputs. Rows include Method, Output frequency, Speed control, Analog, Digital.

Table 10: List of models of CFW300 series, main electrical specifications

Large table listing electrical specifications for various CFW300 models. Columns include: Inverter, Power Supply Rated Voltage, Frame size, Output Rated Current, Maximum Motor, Rated Carrier Frequency, Nominal Inverter Switching Frequency, Power Wire Size, Grounding Wire Size, Dynamic Braking, Fuses and Circuit Breakers for Inverter Protection.

- Notes: (1) Ranges 1 and 2 only for 400 V Line. (2) Range 1: Grid supply voltage: 380-400-415 Vac (513-540-560 Vdc). (3) Range 2: Grid supply voltage: 440-460-480 Vac (594-621-650 Vdc). (4) For inverter's semiconductor protection, use the WEG recommended class aR semiconductor fuses (P < maximum I). (5) In order to comply with UL508C standard, use UL class J, 600 V fuses. (6) In order to comply with UL508C standard, use the accessories LST25 and TSB-22, required for MPW motor protector be Manual Self-Protected (Type E) Combination Motor Controller. (7) Manual Self-Protected (Type E) Combination Motor Controller, UL listed for 200 - 240 V and 480Y/277 V systems. Not UL listed for use on 480 V Delta/Delta systems, corner ground, or high-impedance ground systems (IT system). (8) Largest WEG MPW circuit breaker recommended. (9) Standard Fault level. To apply the CFW300 with MPW circuit breaker (or Type E) in power supplies with short circuit current levels higher than this (High Fault level up to 65 kA), please refer to Item 3.2.3.1.1 Short Circuit Current Ratings (SCCR) of the user's manual for proper configuration. (10) For DC power supply, please refer to Item 3.2.3.1.1 Short Circuit Current Ratings (SCCR) of the user's manual for proper configuration of protection.

Table with 3 columns: Outputs, Safety, Integral keypad (I+M), Enclosure. Rows include Relay, Power supply, Protection, Standard keypad, IP20.

11 CODES AND STANDARDS

Table 9: Codes and standards. Columns: Safety standards, Mechanical standards, Electromagnetic compatibility (EMC) standards. Lists various standards like UL 508C, IEC 61800-3, CISPR 11, etc.

(*) Compliance with standards upon installation of RFI filter. For further details refer to user's manual available for download on the website: www.weg.net.